

VALOISTE-OULU LED

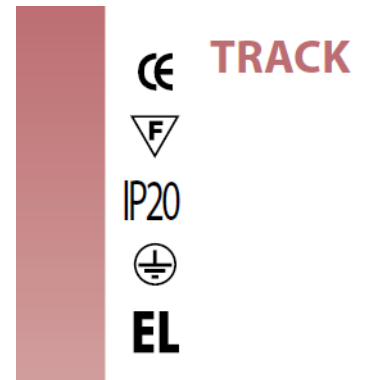

230V/50Hz LED

1. Dimensions, weight

Power [W]	Weight	A [mm]	B [mm]
44W PRO LED	6,8 kg	1368	1240

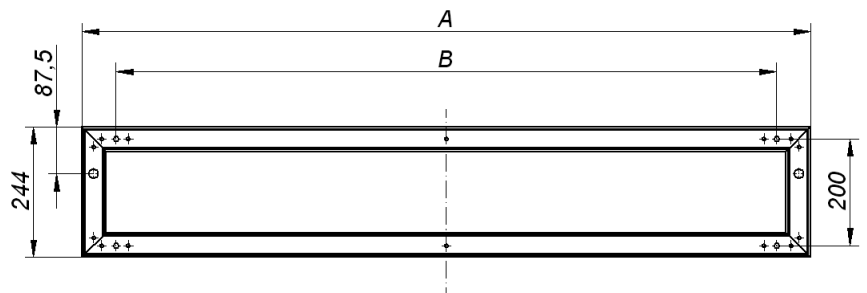

2. Installation

a) take the louver out of the fixture (PAR) or screw the back cover of the fixture off (O/P),

b) lever and remove the shorter closing flap,

c) pull the feeding cable through the hole in the flap and connect it as shown on a cube,

d) in case of system installation, electric connection of neighbor fixtures should be done through the holes in the side of housings, fixtures should be also connected mechanically,

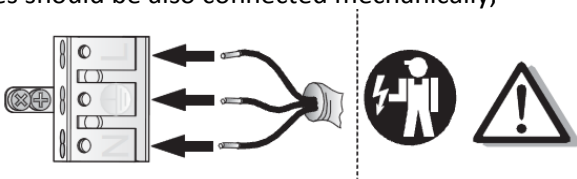
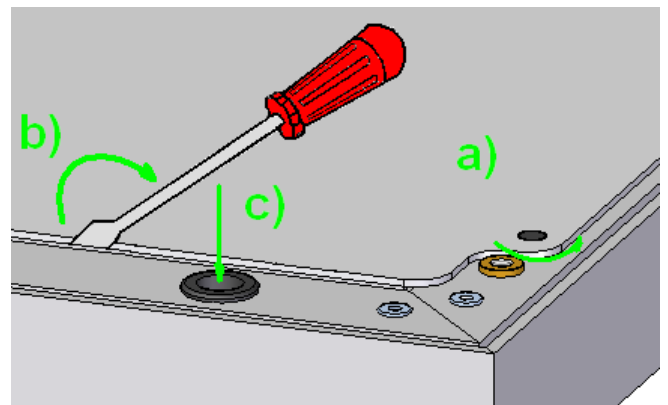

e) suspension mounting:

- screw universal suspension into the ceiling, unscrew external nut lightly, put the line in until obtaining optimum level of suspension and screw nut on. Putting line deeper cause fixture lifting. In order to lower fixture loosen nut And press on – line will pull out



ATTENTION! Each fixture should be suspended on a separate set of lines.

f) fluorescent lamp mounting

- put fluorescent lamp in the fixture and into the sockets with soft pressure and close fixing,
- rotate fluorescent lamp by 90°,
- place and screw back cover of the fixture (O/P) or put in the louver (PAR)

3. Important warnings:

The manufacturer cannot be considered liable for any damages deriving from improper, wrong and unreasonable use of the fitting.

Luminaries may be installed by qualified personnel only.

Any manipulation inside the luminaire when power supply is on causes the risk of electric shock.

Manufacturer is not responsible for any flaws caused by avoid using this manual.

Manufacturer reserves a right to change the construction of the product.

Do not assembly in places without air circulation.

To guarantee safety of fixture functions, please assembly according to instruction.



The European Directive 2002/96/EC on waste electrical and electronic equipment, requires that electric and electronic devices must be disposed of in the normal household waste. The crossed out wheeled bin is reproduced in order to remember obligations towards separately collection. For correct disposal, please use authorized waste disposal facilities or returned to the distributor at the date a new lighting fitting is purchased. Lamps, if disposed together with the lighting fitting, shall not be broken up since they contain substances which are highly polluting for the environment. Unauthorized disposal of the foregoing waste material is punishable by law. More details of directive available at: <http://www.gios.gov.pl>

