

VALOISTE - GRANKULLA LED

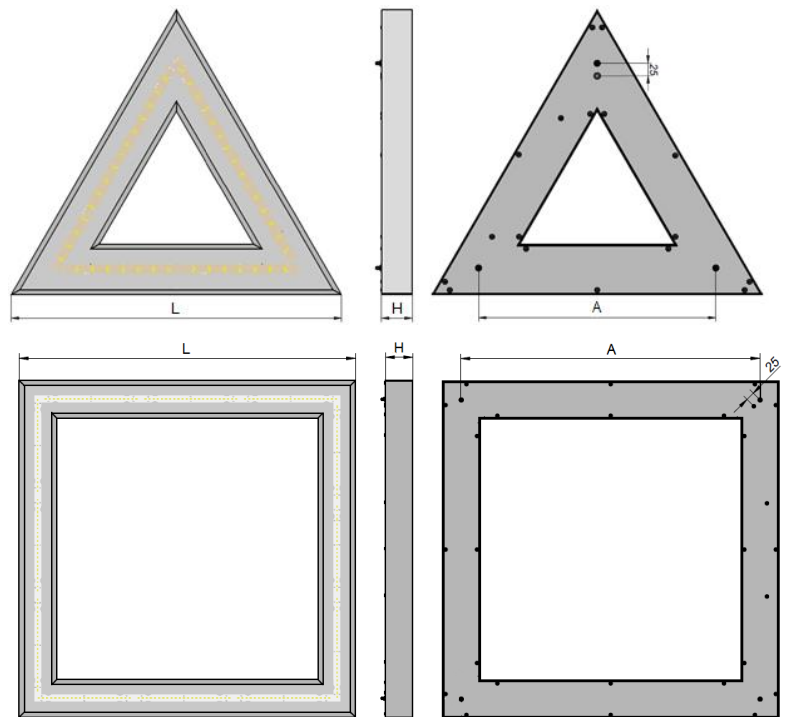
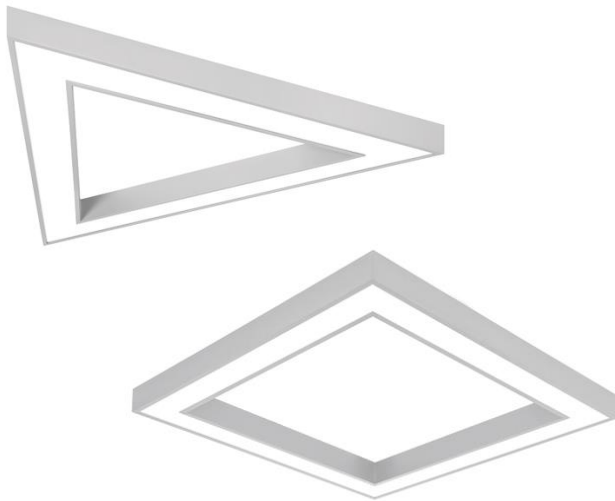

230V/50HZ LED

1. Dimensions

Model	Power [W]	L	A	H	Weight(kg)
Δ	44	650	467	60	3,5
Δ	77	1065	865	80	8,5
□	70	680	580	60	5,5
□	102	980	870	80	11,0

2. Installation

a) carefully take the luminaire out of the package and put it on a stable surface (e.g. floor, table)

b) attaching the luminaire to a ceiling/electrical connection:

- pull the cable through the electric suspension base (Fig.1)
- use the 2 rawplugs and screws to screw the electric suspension base to the ceiling (place the rawplugs diagonally from one another)
- using the "A" distance attach the simple suspension to the ceiling (Fig.2).

c) suspension and attaching the luminaire's suspension length:

- Loosen the regulator's outer nut, slide the regulator up or down the line till the desired suspension height is obtained and tighten the nut.
- To raise the luminaire slide the regulator up the line; to lower the device, loosen the regulator's nut and push it in, this will release the line.

d) electrical connection:

- connect the wiring as indicated by the colours.

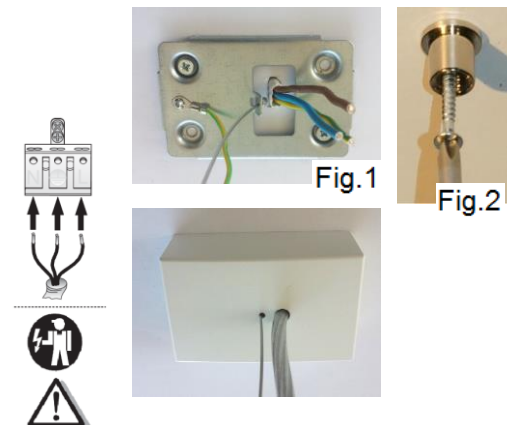

3. Important warnings:

Luminaires may be installed by qualified registered personnel only.

Any manipulation inside the luminaire when the power is activated causes the risk of electric shock.

The manufacturer is not responsible for any flaws resulting from non-compliance with these instructions.

The manufacturer reserves the right to change the construction of the product.

Do not install the luminaire in places without sufficient air circulation.

To guarantee safe luminaire functioning, please follow the instructions in the installation instructions.



The European Directive 2002/96/EC on waste electrical and electronic equipment, requires that electric and electronic devices must not be disposed of in the normal household waste. The crossed out wheeled bin is reproduced in order to remind obligations towards separate collection. For correct disposal, please use authorized waste disposal facilities or return to the distributor at the date a new lighting fitting is purchased. Lamps, if disposed together with the lighting fitting, shall not be broken up since they contain substances which are highly polluting to the environment. Unauthorized disposal of the foregoing waste material is punishable by law.

For the Directive details please visit: <http://eur-lex.europa.eu/legal-content/en/ALL/?uri=CELEX:32002L0096>

