

VALOISTE - FINESSE LED

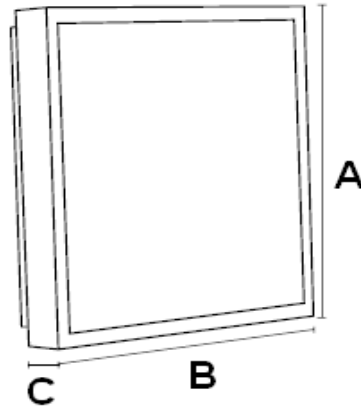

230V/50HZ

1. Dimensions and weight

Power	A	B	C	Weight
LED 10W	307	307	68	3kg
LED 10W INOX	337	337	65	2,1kg
LED 19W	407	407	65	3,8kg
LED 19W INOX	437	437	65	3,8kg



2. Assembly

- take out carefully fixture from packaging and put in safety place (table or floor)
- fasten screws off (besides of INOX) to take cover of fixture off
- take frame with sheet/plate
- place expand pegs according to holes in base of fixture (wall/ ceiling mounting)
- screw four regulation lines in hole sof ceiling assembly (for wires/chain fixture)
- power connection
 - put power cable through the hole in base of frame
 - connect cables according to sings at power cube

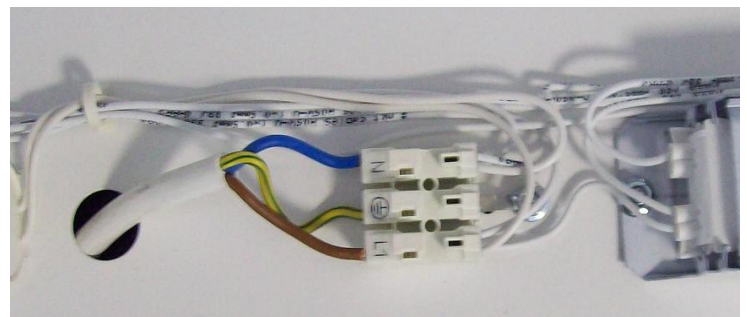
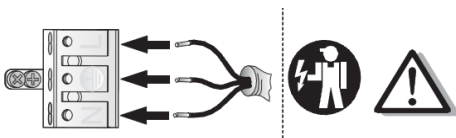

g) wall/ceiling and wires/chain mounting

- wall/ceiling mounting: fixture assembly to ceiling or wall with four holes of 7mm diameter, label at side of base show direction of suspension (wall mounting INOX)

Power	A	B	C	Weight
LED 10W	307	307	68	3kg
LED 10W INOX	337	337	65	2,1kg
LED 19W	407	407	65	3,8kg
LED 19W INOX	437	437	65	3,8kg

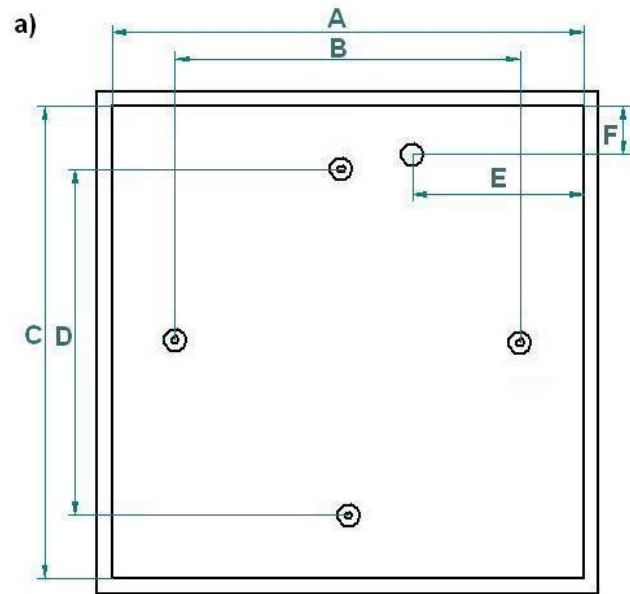

- wall/chain mounting:

drill the mounting holes for 8mm diameter, screw suspension universal to ceiling, screw tightly outside nut of regulation in the mounting hole, place the line until the moment you reach needed lengths and screw nut on again.

Placing the line deeply it makes fixture up.

If you need to make fixture down screw nut of regulation off and put in fixture – line will go down.

h) fluorescent lamp mounting:

- lamps of correct power put to the fixture

i) put (INOX) and screw cover of fixture again

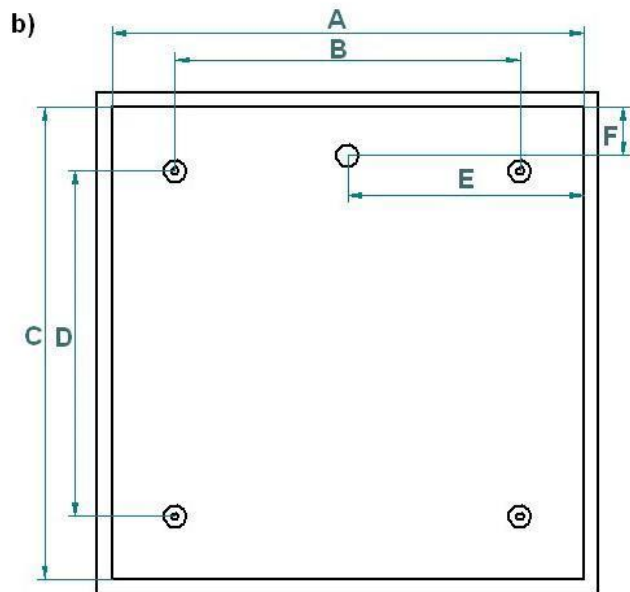

3. Important warnings:

- the manufacturer cannot be considered liable for any damages deriving from improper, wrong and unreasonable use of the fitting.

- luminaries may be installed by qualified personnel only.

- any manipulation inside the luminaire when power supply is on causes the risk of electric shock.

- manufacturer is not responsible for any flaws caused by a void using this manual.

- manufacturer reserves a right to change the construction of the product.



The European Directive 2002/96/EC on waste electrical and electronic equipment, requires that electric and electronic devices must be disposed of in the normal household waste. The crossed out wheeled bin is reproduced in order to remember obligations towards separately collection. For correct disposal, please use authorized waste disposal facilities or returned to the distributor at the date a new lighting fitting is purchased. Lamps, if disposed together with the lighting fitting, shall not be broken up since they contain substances which are highly polluting for the environment. Unauthorized disposal of the foregoing waste material is punishable by law. More details of directive available at: <http://www.gios.gov.pl>

